

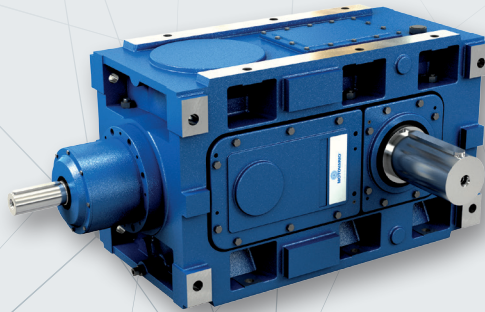

NEW

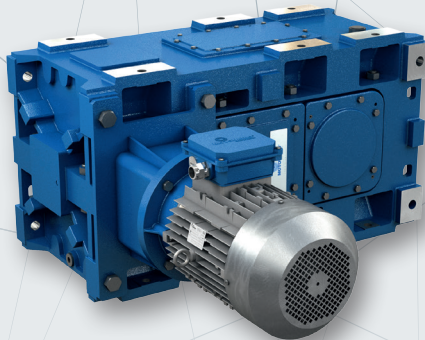

PARALLEL HELICAL AND BEVEL HELICAL GEARBOXES



MOTOVARIO[®]
HEART OF MOTION

a TECO Group company



1 pag. 4
Introduction

2 pag. 5
Features

3 pag. 6
Versions

4 pag. 7
Range and
designation

5 pag. 9
Executions

6 pag. 10
Method
of selection

7 pag. 17
Manufacturing
program

8 pag. 35
Accessories

1

INTRODUCTION

The Motovario PBH series of gearboxes for heavy industries, is a range of parallel and bevel helical gearboxes up to 4 reduction stages, built as standard and designed specifically to ensure maximum reliability in the most arduous conditions.

PBH series reducers present the classic features of parallel and bevel helical gear reducers such as robustness, efficiency, compactness and reliability, combined with universality, ease of application and low maintenance which are a result of a modern design concept, typical of quality reducers.

MAIN FEATURES OF THE PBH SERIES:

- Universal mounting: suitable for horizontal or vertical mounting
- Cast iron casing, rigid and with great lubricant capacity to enhance the thermal capacity
- Casing split in two parts, with reduced and direct maintenance
- Standard solid low speed shaft, with standard and double extension
- Possibility of double extended high speed shaft
- Possibility of fitting large size motors
- IEC standard motor, with the possibility of coupling NEMA motors
- High endurance of loads on both low and high speed shaft end
- High performances, reliable and tested.

2

FEATURES

SIZES AND TRAIN OF GEARS

AVAILABLE SIZES: 180, 200, 225, 250, 280, 320, 355

Train of gears: 1, 2, 3 and 4 stages for parallel helical reducers
2, 3 and 4 stages for bevel helical reducers.

MATERIALS (CASING, GEARS AND SHAFTS)

Casing: 200 UNI ISO 185 cast iron

Gears and pinions: 16CrMo4, 15NiCr13, 17CrNiMo6 hardened and casehardened steel

Low speed shafts: 42CrMo4 hardened steel.

EXTERNAL PAINTING

Electrostatically paint with epoxy polyester powder, minimum dry thickness 80 microns. Blue color RAL 5010

LUBRICANT OIL AND LUBRICATION

Motovario PBH gear reducers have been designed to be lubricated by oil splash. Unless otherwise specified, PBH gear reducers are supplied without oil and it is responsibility of the Customer to fill them to the specified level with **mineral oil**. In order to increase the oil change interval, the ambient temperature range, or to reduce the oil temperature, it is always recommended to use **synthetic oil** with **polyglycol basis** or with **polyalphaolefines basis**.

Suggested **mineral oils**:

ENI Blasia, ESSO Spartan EP, MOBIL Mobilgear, SHELL Omala, Klüberoil GEM1, TOTAL Carter EP.

Suggested **synthetic** oils with **polyglycol basis**:

KLÜBER Klübersynth GH6, ENI Blasia S, MOBIL Glygoyle, SHELL Tivela S;

or with **polyalphaolefines basis**:

SHELL Omala HD, AGIP Blasia SX, KLÜBER Klübersynth EG4, CASTROL Tribol 1510, ELF Reductelf SYNTHÈSE, ESSO Spartan SEP, KLÜBER Klübersynth EG4, MOBIL SHC Molykote.

3 VERSIONS

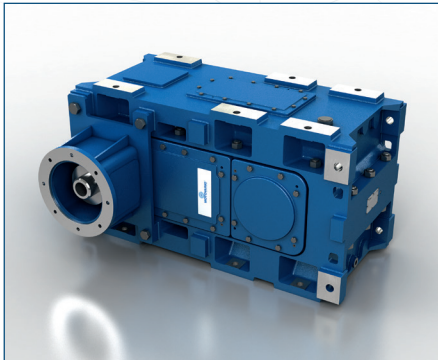

Parallel Helical
Bell coupling input without motor

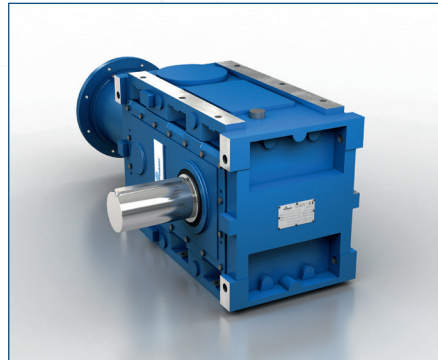

Bevel Helical
Bell coupling input without motor

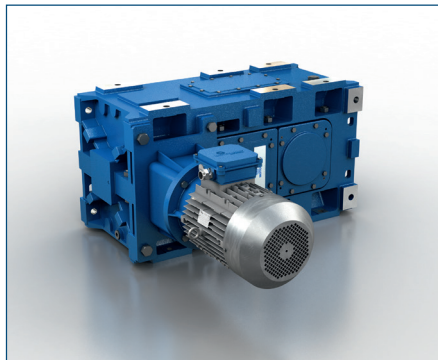

Parallel Helical
Bell coupling input with motor

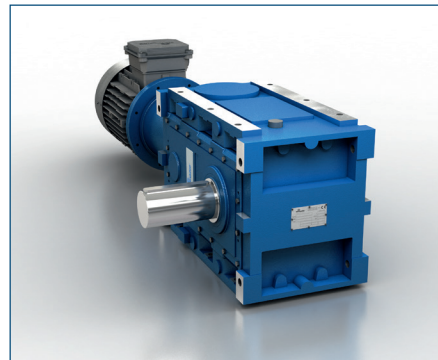

Bevel Helical
Bell coupling input with motor

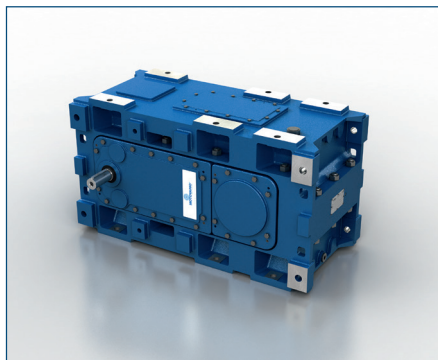

Parallel Helical
Male input shaft

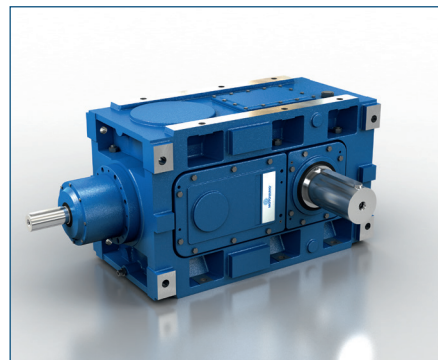

Bevel Helical
Male input shaft

4

RANGE AND DESIGNATION

RANGE

Size	Output nominal torque M_{N2} [Nm]	Transmission ratio	
	Max	Min	Max
PH 180	12400	1,26	762
PH 200	16800	1,22	659
PH 225	24900	1,28	676
PH 250	31000	1,23	710
PH 280	40400	1,27	708
PH 320	50000	1,25	710
PH 355	78400	1,26	708

Size	Output nominal torque M_{N2} [Nm]	Transmission ratio	
	Max	Min	Max
BH 180	12200	5,81	727
BH 200	16900	5,81	660
BH 225	23000	5,20	669
BH 250	29000	5,31	710
BH 280	40000	5,81	676
BH 320	49000	5,60	710
BH 355	76600	5,60	685

DESIGNATION

PBH	P	1H	180	AU	I	d1 x l1	HC	DxL	1,22	B3
	B	2H	200	AZ	P	d x P	HL		.	B6
		3H	225	DU			HS		.	B7
		4H	250	DZ			CS		.	B8
			280	LR			SS		762,36	V5
			320	LL			CD			V6
			355	SR			SD			
				SL						
				DR						
				DL						

Series

Type
 P: Parallel helical reducer
 B: Bevel helical reducer

Train of gears

Size

Execution

Input
 I: Male input shaft
 P: Bell coupling input

Output

HC: Hollow low speed shaft with keyway
 HL: Hollow low speed shaft with shrink disk
 HS: Splined hollow low speed shaft
 CS: Cylindrical solid low speed shaft
 SS: Splined solid low speed shaft
 CD: Cylindrical double extended solid low speed shaft
 SD: Splined double extended solid low speed shaft

Input dimensions

Output dimensions

Mounting position

Transmission ratio

5 EXECUTIONS

PARALLEL HELICAL

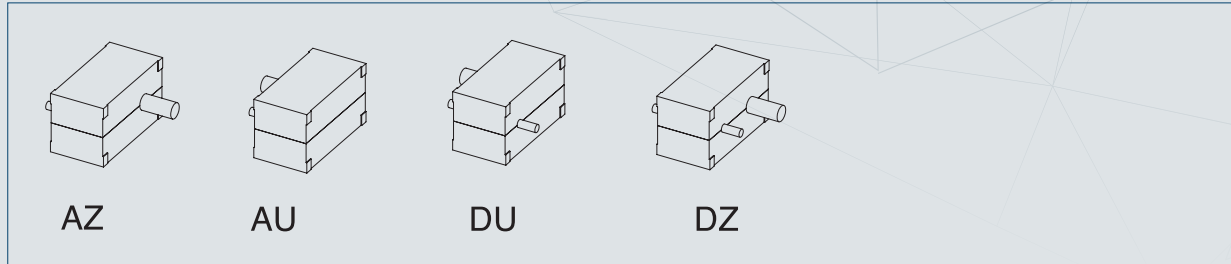

BEVEL HELICAL

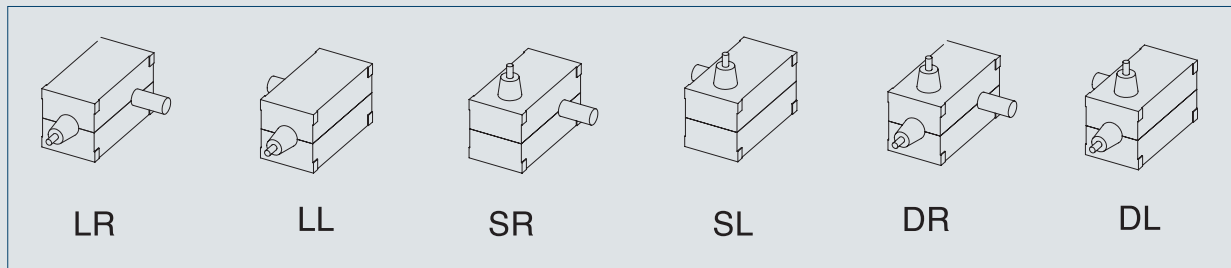

MOUNTING POSITIONS - PARALLEL HELICAL

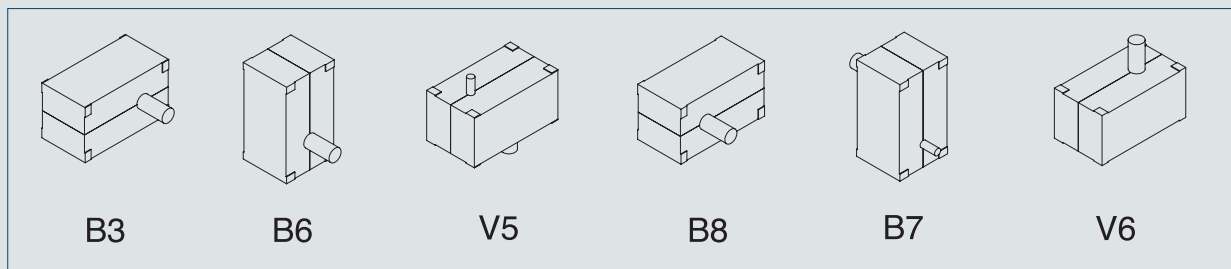

MOUNTING POSITIONS - BEVEL HELICAL

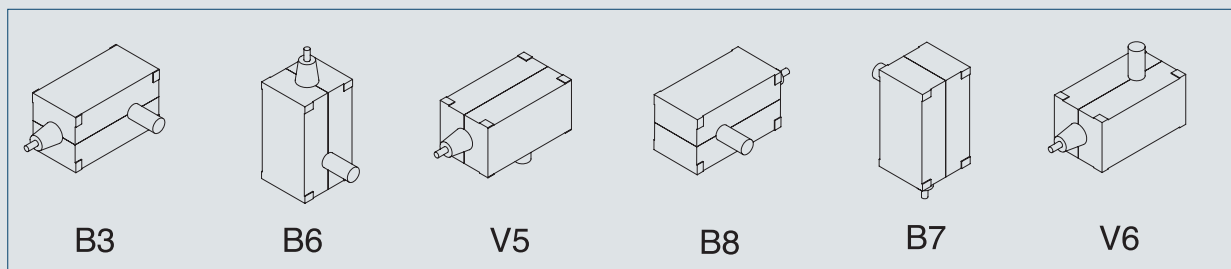

6

METHOD OF SELECTION

LEGEND

i_N = nominal transmission ratio

i = effective transmission ratio

n_1 = input speed [rpm]

n_2 = output speed [rpm]

f_s = service factor required by the application

f_a = service factor according to classification of load and daily working hours

f_b = service factor according to number of starts per hour

f_c = service factor according to motor installed type

P_{th} = nominal thermal power (kW)

t_a = thermal factor according to ambient temperature and intermittent duty

t_b = thermal factor according , depending on cooling fan

T_{amb} = ambient temperature [°C]

P_{N1} = nominal power at high speed shaft [kW]

M_{N2} = nominal output torque at low speed shaft [Nm]

P_1 = input power [kW]

M_2 = output torque at low speed shaft [Nm]

M_{2max} = overload torque at low speed shaft [Nm]

6

METHOD OF SELECTION

- 1) Calculate the required transmission ratio $i = n_1 / n_2$
- 2) Calculate the available torque at low speed shaft $M_2 = P_1 * 9550 * \eta / n_2$ [Nm]
- 3) Define the minimum service factor f_s required by the application based on:
 - Classification of load (uniform, moderate, heavy)
 - Daily working hours [h/d]
 - Number of starts / hour [starts / hour]
 - Type of installed motorSee tables 1, 2, 3 e 4.
- 4) Define the minimum reducer performance $M_{N2} = M_2 * f_s$ [Nm]
- 5) Select the reducer size, train of gears and transmission ratio based on M_{N2} , n_2 and n_1

Verifications

- a) Verify the thermal power. See tables 5, 6 and 7.
- b) When there are overloads due to starting on full power, braking, high inertia loads, check the overload torque (**M_{2max}**) $M_{2max} \leq 1,8 * M_{N2}$
Note: overloads are instantaneous peaks (maximum acceptable duration 10 seconds)
- c) For radial and / or axial loads on high and low speed shaft, please contact us.
- d) Contact Motovario technical service for:

- $n_1 > 1000$ rpm for P1H and B2H
- $n_1 > 1750$ rpm P2H, P3H and B3H
- $n_1 > 2000$ rpm for P4H and B4H

Service factor

The minimum service factor required by the application is defined as

$$f_s = f_a * f_b * f_c$$

Table 1: classification of load

6 METHOD OF SELECTION

TABLE N. 1 CLASSIFICATION OF LOADS

<u>Applications</u>	<u>Type of load</u>	<u>Applications</u>	<u>Type of load</u>
CONVEYORS		FOOD INDUSTRIES	
(for heavy and not uniform loads)		Mixers	Moderate
Scraper or scoop	Moderate	Kneading machines	Moderate
Belt	Moderate	Beaters	Moderate
Buckets	Moderate	Meat choppers	Moderate
Elevators	Moderate		
Rollers	Moderate	COMPRESSORS	
For furnaces	Moderate	Centrifugal	Uniform
Reciprocating	Heavy	Lobulated	Moderate
Jerking	Heavy	Reciprocating with multiple cylinders with suitable flywheel	Moderate
Screws	Heavy	Reciprocating with single cylinder	Heavy
MACHINE TOOLS		RUBBER INDUSTRIES	
Punching presses	Heavy	Mixers	Heavy
Shears	Heavy	Calenders for rubber	Heavy
Planes	Heavy	Rolling mills	Heavy
Main movements Ancillary Movements (feeders, advances, etc.)	Moderate Uniform	Machinery for tyres	Moderate
PUMPS		SIEVES	
Centrifugal	Moderate	Rotary (sand or stone)	Moderate
Rotating and geared	Uniform	Reciprocating	Moderate
(for heavy and not uniform loads) (variable density)	Moderate		
Reciprocating with free unloading	Uniform	AGITATORS	
Reciprocating with multiple cylinders double-acting	Moderate	Semi-liquid	Moderate
Reciprocating with single cylinder	Heavy	Variable density	Moderate
LIFTS		MACHINE FOR THE TEXTILE INDUSTRY	
Types similar to transporters	Moderate	Washing mills	Moderate
Goods lifts-Freight	Moderate	Calenders	Moderate
Passenger	Heavy	Cards	Moderate
		Machines for dyeing	Moderate
PAPER INDUSTRIES		Looms	Moderate
Mixers (agitation)	Moderate	Pickers	Moderate
Conveyors	Moderate	Spinning machines	Moderate
Cylinders	Moderate		
Felt tighteners	Moderate	DREDGERS	
Calenders	Heavy	Cable drum	Moderate
Presses	Heavy	Conveyors	Moderate
Winders	Heavy	Pumps	Moderate
		Stackers	Moderate
		Goods lifts	Moderate
		Sieves	Heavy
		Buckets	Heavy

6

METHOD OF SELECTION

TABLE N. 1 CLASSIFICATION OF LOADS

Applications	Type of load	Applications	Type of load
FANS (uniform speed and balanced)		TRANSMISSIONS	
Centrifugal	Uniform	For industrial equipment machines	Moderate
Light, with small diameter	Uniform	Subgroup movement	Moderate
For cooling towers	Moderate	Secondary transmissions	Uniform
For forced air flow	Moderate		
For mines	Moderate		
CRANES		CRUSHERS	
Derrick	Uniform	Mineral	Moderate
Slewing	Uniform	Stone	Moderate
Transfer movement	Moderate		
Drum movement	Heavy		
METAL INDUSTRIES		MILLS (rotary type)	
Drawing benches	Heavy	Ball	Heavy
Stamping presses	Heavy	Hammer	Heavy
Cutting machines	Heavy	Ring roll	Heavy
Small rolling machines	Heavy	For cement	Moderate
MIXERS		PACKING MACHINES	
Constant density	Uniform		Uniform
Irregular density	Moderate	WASHING MACHINES AND PUMPS	
Concrete	Moderate		Moderate

6 METHOD OF SELECTION

TABLE N. 2 fa SERVICE FACTOR ACCORDING TO CLASSIFICATION OF LOAD AND DAILY WORKING HOURS

	2 h/d	4 h/d	8 h/d	16 h/d	24 h/d
Uniform	0,80	0,90	1,00	1,25	1,35
Moderate	1,00	1,15	1,25	1,50	1,75
Heavy	1,25	1,50	1,75	2,00	2,25

TABLE N. 3 fb SERVICE FACTOR ACCORDING TO NUMBER OF STARTS / HOUR

	< 8 starts/h	8..32 starts /h	32..64 starts /h	64 ..128 starts /h
Uniform	1,00	1,25	1,35	1,50
Moderate	1,00	1,15	1,25	1,35
Heavy	1,00	1,05	1,15	1,25

TABLE N. 4 fc SERVICE FACTOR ACCORDING TO MOTOR INSTALLED TYPE

Electric motor	1,00
Explosion motor multiple cylinders	1,15
Explosion motor single cylinder	1,25

6.1 THERMAL POWER

The nominal thermal power (Pth), table 5, is the power that can be applied to reducer high speed shaft without exceeding approximately 95°C of oil temperature, in the following reference conditions:

- Mounting position B3
- Continuous operation
- Input speed ≤ 1500 rpm
- Ambient temperature 20°C
- Sea level altitude
- Air speed near the gear reducer ≥ 1 m/s
- Absence of external radial and / or axial loads

Except for continuous operating times below 2 hours and successive pauses capable of bringing the gear reducer back to ambient temperature (1-2 hours) , for each application is advisable to verify the gear reducer's thermal limit according to the following formula:

$$P_1 < P_{th} * t_a * t_b$$

Nominal thermal power Pth [kW] Reducer size							
Size Type	180	200	225	250	280	320	355
P1H	155	188	230	294	360	440	552
P2H	96	116	142	184	228	268	344
P3H	73	89	109	141	170	207	272
P4H	56	68	83	108	130	158	208
B2H	92	110	135	175	217	250	327
B3H	70	85	103	134	162	190	259
B4H	53	65	79	103	124	145	198

6.1 THERMAL POWER

TABLE N. 6 THERMAL FACTOR t_a , ACCORDING TO AMBIENT TEMPERATURE AND INTERMITTENT DUTY

T_amb	Intermittent duty [%]				
	100%	80%	60%	40%	20%
10°C	1,15	1,25	1,35	1,5	2
20°C	1	1,05	1,15	1,35	1,75
30°C	0,9	1,00	1,05	1,25	1,50
40°C	0,75	0,8	0,9	1	1,35
50°C	0,6	0,63	0,7	0,8	1

TABLE N. 7 THERMAL FACTOR t_b , DEPENDING ON COOLING FAN

All sizes - Parallel helical		
Train of gears	Input speed [rpm]	t_b
P1H P2H	n1= 1500	1,5
P3H P4H	n1= 1000	1,12

All sizes - Bevel helical		
Train of gears	Input speed [rpm]	t_b
B2H B3H	n1= 1500	1,75
B4H	n1= 1000	1,35

7 MANUFACTURING PROGRAM

Performances

PARALLEL HELICAL REDUCERS - P1H (SINGLE STAGE)

			Gear reducer size						
			i						
			M _{N2} Nm						
			P _{N1} kW						
P1H - n ₁ = 1500 min ⁻¹	n _{N2}	i _N	180	200	225	250	280	320*	355
	1200	1,25	1,26	1,22	1,28	1,23	1,27	1,25	1,26
			7300	10200	14200	16600	25000	31000	41600
			934	1337	1777	2158	3150	3900	5290
	1071	1,4	1,41	1,37	1,43	1,41	1,43	1,4	1,41
			7900	10700	15200	17500	26300	32000	45200
			903	1254	1708	1993	2946	3600	5134
	938	1,6	1,59	1,63	1,61	1,59	1,62	1,6	1,57
			8600	11500	16000	18400	27700	34000	48600
			870	1131	1596	1859	2740	3350	4964
	833	1,8	1,8	1,84	1,81	1,8	1,83	1,8	1,75
			9400	12000	16800	19400	28900	36000	52200
			835	1048	1485	1724	2533	3150	4784
	750	2	2,04	1,96	2,04	2,04	1,96	2	1,96
			10100	12300	17500	20200	29700	37000	56100
			796	1007	1372	1588	2430	2910	4591
	670	2,24	2,18	2,23	2,17	2,18	2,29	2,24	2,21
			10500	12900	17800	20700	32800	41000	60500
			771	924	1316	1521	2294	2890	4387
	600	2,5	2,55	2,55	2,48	2,52	2,55	2,5	2,5
11400			13800	18600	22800	33900	42000	65000	
718			870	1203	1450	2131	2650	4168	
536	2,8	2,76	2,76	2,84	2,86	2,76	2,8	2,85	
		11600	14100	19300	23700	34600	43000	67500	
		671	822	1090	1326	2010	2430	3795	
476	3,15	3,11	3,11	3,06	3,1	3,11	3,15	3,14	
		11100	14600	19700	24100	35800	44000	71800	
		571	754	1033	1247	1844	2210	3663	
423	3,55	3,63	3,58	3,56	3,5	3,6	3,55	3,57	
		10300	14100	19400	24800	36700	45000	72800	
		454	629	872	1137	1635	2010	3270	
375	4	3,89	4,12	3,89	3,94	4,06	4	4	
		9900	12900	18700	25300	34500	43000	67400	
		406	501	772	1029	1362	1700	2699	
333	4,5	4,5	4,5	4,5	4,56	4,41	4,5	4,56	
		8900	12200	16900	22800	32500	40000	63600	
		316	435	602	800	1183	1410	2236	
300	5	4,94	5,12	5,13	5,13	5,07	5	4,88	
		8400	11000	15400	21000	29100	36000	60100	
		272	343	482	656	919	1150	1973	
268	5,6	5,73	5,53	5,53	5,53	5,67	5,6	5,67	
		7300	11300	14400	19500	26700	33000	52800	
		205	327	417	567	756	940	1494	

* For this size please contact Technical Support

PARALLEL HELICAL REDUCERS - P2H (DOUBLE STAGE)

			Gear reducer size						
			i						
			M _{N2} Nm						
			P _{N1} kW						
P2H - n ₁ = 1500 min ⁻¹	n _{N2}	i _N	180	200	225	250	280	320*	355
	268	5,6	5,42	5,41	5,68	5,84	5,52	5,6	5,7
			11500	15900	22000	28900	38000	47000	62800
			348	481	634	810	1128	1330	1804
	238	6,3	6,09	6,09	6,11	6,34	6,21	6,3	6,29
			11200	15200	21300	29100	40100	50000	67300
			300	408	571	750	1057	1260	1751
	211	7,1	7,12	7,01	6,96	7,16	7,22	7,1	7,16
			10400	14200	19300	27200	37700	47000	70000
			240	332	454	623	854	1050	1608
	188	8	7,87	8,06	7,92	7,94	8,02	8	7,98
			11400	14000	22000	27100	40400	50000	68000
			237	284	454	558	825	1000	1399
	167	9	8,54	8,75	9,09	9	8,7	9	9,09
			12000	15200	22500	29500	40400	50000	72200
			230	284	405	537	760	890	1299
	150	10	9,6	9,83	9,78	9,77	9,78	10	10,0
			11500	15500	21800	29800	40400	50000	77600
			196	259	365	498	677	800	1266
	134	11,2	11,2	11,3	11,4	11,0	11,3	11,2	11,4
10600			14600	20200	27900	38000	47000	75900	
155			211	289	414	549	670	1087	
120	12,5	12,0	13,0	12,4	12,4	12,8	12,5	12,8	
		10200	13300	19500	26200	35700	44000	69900	
		139	167	256	345	458	570	897	
107	14	14,2	13,5	14,1	13,9	13,6	14	14,3	
		9300	13200	19500	25500	34100	42000	70500	
		108	161	227	300	410	490	810	
94	16	15,9	15,2	15,1	15,1	15,3	16	15,7	
		10500	14900	20900	27600	38400	48000	77700	
		108	161	227	300	410	490	810	
83	18	18,6	17,5	17,6	17,0	17,7	18	17,9	
		10900	14900	20600	28500	38900	48000	77500	
		96	140	191	274	359	430	708	
75	20	19,9	20,1	19,2	19,2	20,0	20	20,0	
		10500	13600	19900	26800	36600	45000	71500	
		86	111	169	229	299	370	585	
67	22,4	23,1	22,0	22,3	22,2	21,7	22,4	22,8	
		9500	13000	18000	24100	34500	43000	67500	
		67	97	132	178	260	320	485	
60	25	25,32	25,01	25,36	24,89	24,97	25	24,41	
		8900	11600	16400	22300	30700	38000	63800	
		57	76	106	146	201	250	428	
54	28	29,38	27,02	27,38	26,88	27,93	28	28,33	
		7900	10900	15300	20800	28400	35000	56000	
		44	66	91	127	166	210	323	

* For this size please contact Technical Support

PARALLEL HELICAL REDUCERS - P3H (TRIPLE STAGE)

			Gear reducer size						
			i						
			M _{N2} Nm						
			P _{N1} kW						
P3H - n ₁ = 1500 min ⁻¹	n _{N2}	i _N	180	200	225	250	280	320*	355
	60	25	24,0	25,0	24,8	24,6	24,8	25	25,5
			11700	14500	19700	28100	38400	48000	78300
			81	97	133	191	259	320	513
	54	28	29,3	27,16	28,94	27,82	26,93	28	29,1
			12000	15700	23400	30600	39700	49000	78300
			68	97	135	184	246	290	450
	48	31,5	32,5	30,5	31,1	30,2	30,3	31,5	32,1
			10700	16100	22700	30800	39700	49000	78400
			55	88	122	171	219	260	408
	42	35,5	34,3	34,2	35,9	34,1	35,1	35,5	36,5
			11100	15100	20800	28900	39500	49000	78200
			54	74	97	142	188	230	358
	38	40	38,0	39,4	38,9	38,4	39,5	40	40,8
			11000	13700	20200	27300	37700	47000	72600
			48	58	87	119	156	200	297
	33	45	43,2	47,1	44,7	46,1	43,0	45	44,9
			9700	15500	20300	28500	35100	43000	78300
			37	55	76	103	136	160	292
	30	50	48,6	49,2	48,1	50,1	48,3	50	49,5
11800			16500	21800	31000	39800	49000	78200	
41			56	76	103	138	165	264	
27	56	56,8	54,3	56,1	56,5	54,9	56	56,4	
		11200	15400	21400	29800	39800	49000	78300	
		33	47	64	88	121	150	231	
24	63	60,8	62,4	61,2	63,7	61,9	63	63,0	
		10800	14000	20600	28100	37900	47000	74100	
		30	37	56	74	102	130	197	
21	71	70,4	68,2	70,8	71,1	67,3	71	70,4	
		9700	13500	18700	27200	35900	44000	74600	
		23	33	44	64	89	105	177	
19	80	80,6	75,8	75,6	77,2	75,6	80	77,6	
		11100	16000	22400	29500	39800	49000	78100	
		23	35	50	64	88	105	168	
17	90	94,2	87,4	88,1	87,1	87,7	90	88,4	
		11800	16100	22000	30400	39800	49000	77900	
		21	31	42	58	76	95	147	
15	100	101	101	96,2	98,1	98,8	100	98,8	
		11300	14600	20900	28400	39000	48000	76100	
		19	24	36	48	66	85	129	
13	112	117	110	111	114	107	112	112	
		10000	13700	19100	25400	36800	46000	71800	
		14	21	29	37	57	70	107	
12	125	128	125	127	128	123	125	121	
		9300	12400	17500	23500	32500	40000	67400	
		12	17	23	31	44	60	94	
11	140	149	135	137	138	138	140	140	
		8300	11600	16200	21800	30000	37000	59900	
		9,4	14	20	26	36	50	72	

* For this size please contact Technical Support

PARALLEL HELICAL REDUCERS - P4H (FOUR STAGE)

			Gear reducer size						
			i						
			M _{N2} Nm						
			P _{N1} kW						
n _{N2}	i _N	Gear reducer size							
		180	200	225	250*	280	320*	355	
15	100	97	100	100	100	98	100	97	
		11900	16800	23700	29000	39000	48000	76400	
		21	29	417	50	68	85	134	
13	112	110	106	114	112	113	112	111	
		11300	15700	21400	26000	38600	48000	76300	
		18	25	32	40	58	70	118	
12	125	122	122	125	125	127	125	124	
		11800	14200	21000	26000	38600	48000	75000	
		17	20	29	35	52	65	103	
11	140	138	145	143	140	136	140	141	
		9800	15900	24900	24900	36700	45000	76500	
		12	19	30	33	46	58	92	
9,4	160	155	152	154	160	153	160	152	
		12000	16700	23800	29000	38400	48000	76600	
		13	19	26	33	43	52	86	
8,3	180	182	176	177	180	177	180	174	
		11700	15800	21700	27000	38800	48000	76000	
		11	15	21	27	37	45	75	
7,5	200	195	192	193	200	199	200	194	
		11800	14800	21200	26000	38500	48000	75000	
		10	13	19	25	33	42	66	
6,7	224	221	230	221	224	216	224	222	
		10300	16300	21300	26000	37700	47000	75700	
		7,9	12	17	21	30	36	58	
6,0	250	249	239	237	250	243	250	244	
		11500	12500	23000	28000	39200	49000	75600	
		7,9	8,9	17	21	28	35	53	
5,4	280	291	265	277	280	282	280	278	
		12000	16400	23200	29000	38100	47000	75300	
		7	11	14	19	23	30	46	
4,8	315	302	304	302	315	318	315	311	
		12000	14900	21400	26000	38900	48000	76200	
		6,8	8,4	12	15	21	27	42	
4,2	355	361	370	350	355	345	355	356	
		10500	16700	19600	24000	37800	47000	75700	
		5	7,7	9,6	14	19	24	36	
3,8	400	413	379	398	400	388	400	393	
		12000	12700	18000	22000	40000	50000	75900	
		5	5,7	7,7	10	18	23	33	
3,3	450	460	426	435	450	450	450	447	
		8600	16700	23300	29000	37700	47000	74900	
		3,2	6,7	9,1	12	14	20	29	
3,0	500	483	490	475	500	507	500	500	
		12400	15200	22300	27000	39200	49000	74100	
		4,4	5,3	8	10	13	18	25	
2,7	560	540	536	550	560	552	560	569	
		11600	14500	20200	25000	39100	48000	77000	
		3,5	4,6	6,3	9	12	16	23	
2,4	630	598	610	626	630	633	630	610	
		10800	13000	18600	23000	34700	43000	70800	
		3,1	3,6	5,1	7	9,4	13	20	
2,1	710	762	659	676	710	708	710	708	
		8800	12300	17000	21000	31900	39000	63900	
		2	3,2	4,3	5,5	7,7	11	15	

P4H - n₁ = 1500 min⁻¹

Dimensional drawings

P1H (SINGLE STAGE) DIMENSIONS (mm)

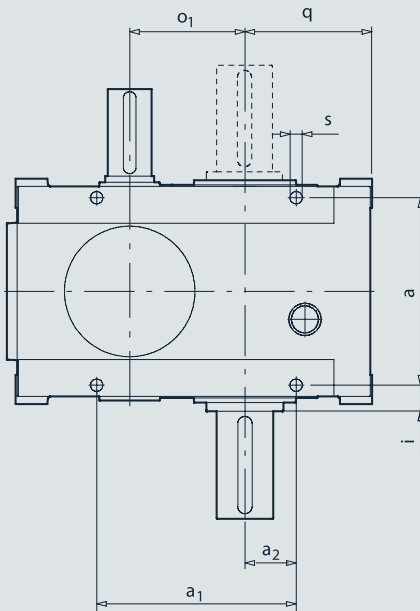
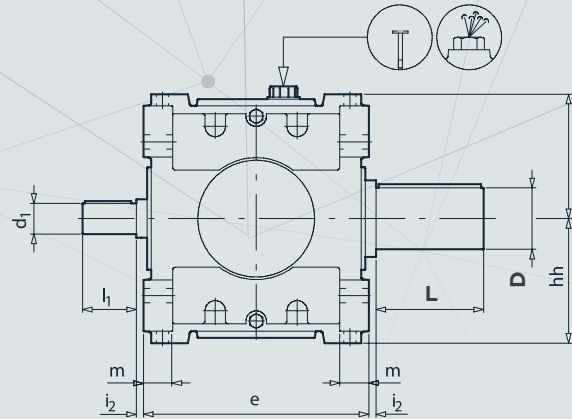
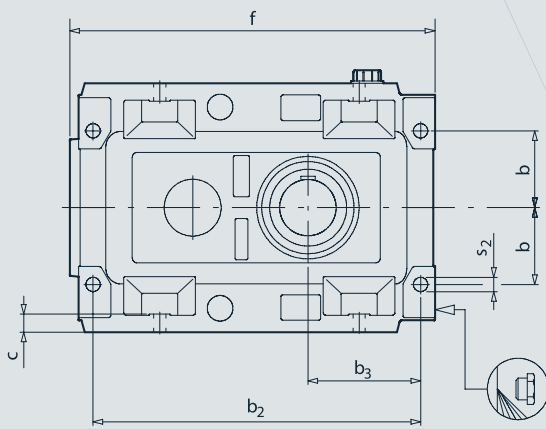

The vent plug-dipstick and drain plug are located according to the operating position.

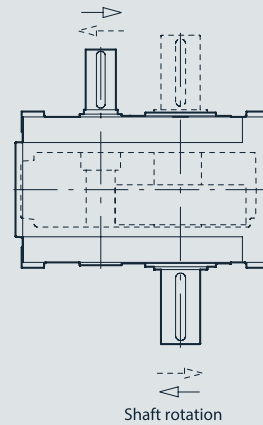

Size	[kg]	Nominal ratio i_n																						
		$i \leq 3,15$										$i > 3,15$												
		a	a ₁	a ₂	b	b ₂	b ₃	c	e	f	h	i	i ₂	m	o ₁	q	s	s ₂	D	L	d ₁	l ₁	d ₁	l ₁
180	365	306	306	85	130	530	190	30	360	591	198	32	5	48	180	210	22	22	100	210	70	140	65	140
200	370	335	353	95	145	577	200	32	400	643	220	37.5	5	53	200	223	22	26	110	210	85	170	70	140
225	585	366	390	100	150	640	220	35	440	713	243	42	5	57	225	248	24	28	120	210	90	170	75	140
250	750	386	450	125	210	720	255	32	480	821	300	52	5	56	250	285	24	28	130	250	110	210	90	170
280	950	430	520	135	230	805	270	34	530	895	320	55	5	60	280	308	26	30	140	250	115	210	95	170
320	1125	470	685	160	240	908	303	34	580	1015	340	60	5	80	320	348	26	32	160	300	120	210	100	210
355	1315	495		200	285		380	45	630		390	72.5	5	60	355	430	35	35	180	300				

Approximate weights are shown in the tables. We reserve the rights to modify any dimensions, without changing the type number of reducers. For missing values please contact Technical Support.

P2H (DOUBLE STAGE) DIMENSIONS (mm)

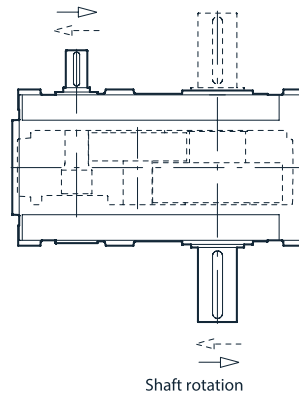
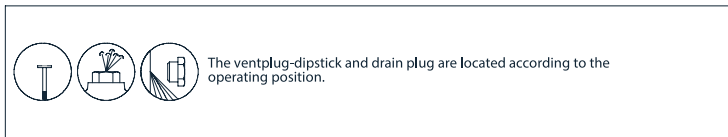
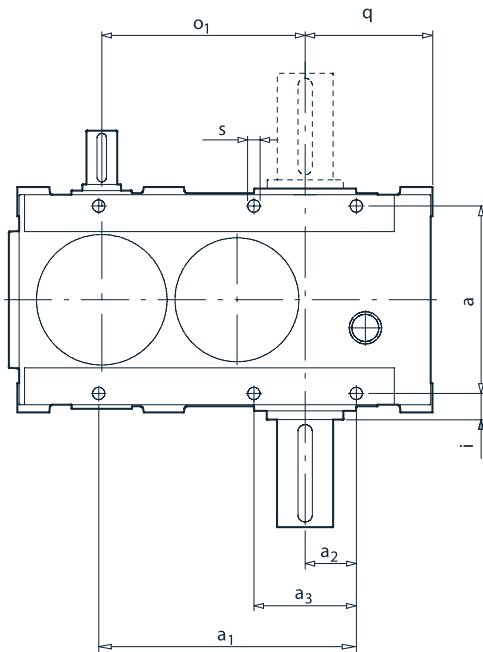
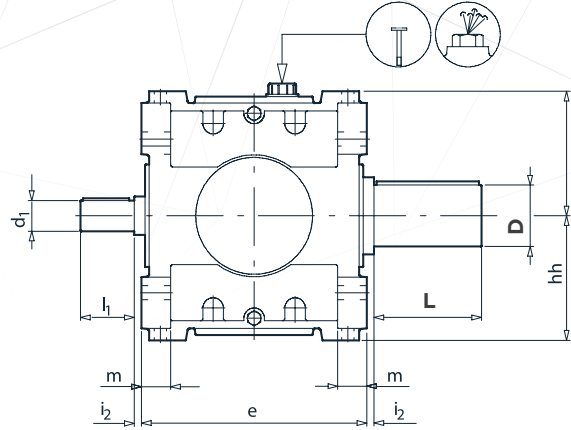
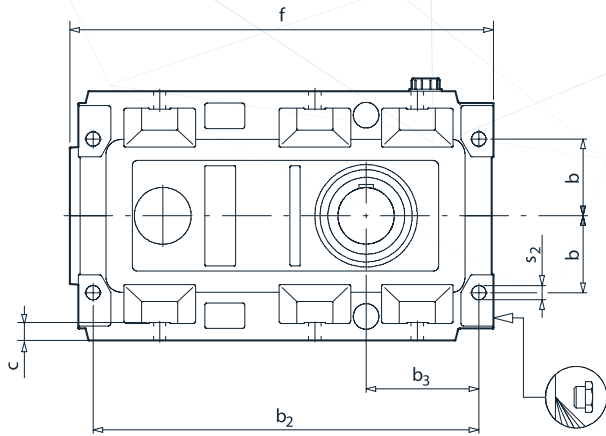

Size [kg]	Nominal ratio i_n																								
	$i < 14$												$i \geq 14$												
	a	a ₁	a ₂	a ₃	b	b ₂	b ₃	c	e	f	h	i	i ₂	m	o ₁	q	s	s ₂	D	L	d ₁	l ₁	d ₁	l ₁	
180	385	306	410	85	-	130	634	190	30	360	695	198	32	5	48	317	210	22	22	100	210	50	110	45	110
200	500	335	450	95	190	145	674	200	32	400	740	220	37.5	5	53	352	223	22	26	110	210	55	110	50	110
225	665	366	503	100	200	150	753	220	35	440	827	243	42	5	57	397	248	24	28	120	210	65	140	60	140
250	855	386	570	125	250	210	830	255	32	480	910	300	52	5	67	440	285	24	28	130	250	70	140	65	140
280	970	430	635	135	270	230	966	270	34	530	1050	320	55	5	80	493	308	26	30	140	250	75	140	70	140
320	1350	470	725	160	320	240	1048	303	34	580	1155	340	60	5	80	554	348	26	32	160	300	80	170	75	140
355	1865	495	825	200	400	285	1220	380	45	630	1335	390	72.5	5	60	625	430	35	35	180	300	90	170	80	170

Approximate weights are shown in the tables. We reserve the rights to modify any dimensions, without changing the type number of reducers. For missing values please contact Technical Support.

P3H (TRIPLE STAGE) DIMENSIONS (mm)

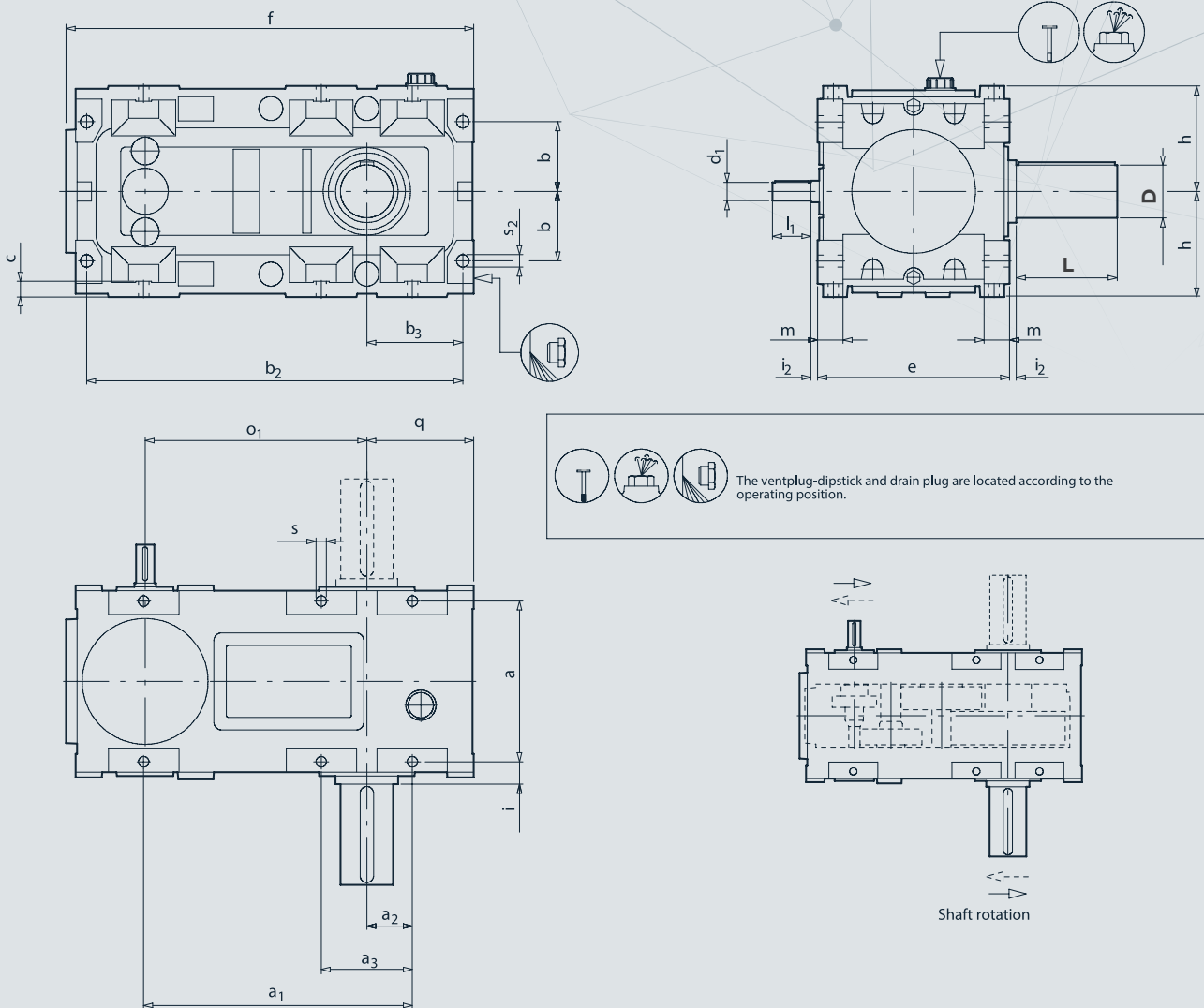

Size	[kg]	a	a ₁	a ₂	a ₃	b	b ₂	b ₃	c	e	f	h	i	i ₂	m	o ₁	q	s	s ₂	D	L	d ₁	l ₁
180	412	306	497	90	180	130	716	190	30	360	777	198	32	5	48	416	210	22	22	100	210	32	80
200	475	335	560	95	190	145	785	200	32	400	845	220	37.5	5	53	462	223	22	26	110	210	38	80
225	715	366	618	100	200	150	868	220	35	440	941	243	42	5	57	527	248	24	28	120	210	42	110
250	1050	386	710	125	270	210	970	255	32	480	1048	300	52	5	67	577	285	24	28	130	250	45	110
280	1320	430	790	135	270	230	1070	270	34	530	1160	320	55	5	60	647	308	26	30	140	250	50	110
320	1650	470	900	160	320	240	1223	303	34	580	1330	340	60	5	80	727	348	26	32	160	300	55	110
355	2090	495	1030	200	400	285	1395	380	45	630	1510	390	72.5	5	60	820	430	35	35	180	300	65	140

Approximate weights are shown in the tables. We reserve the rights to modify any dimensions, without changing the type number of reducers. For missing values please contact Technical Support.

P4H (FOUR STAGE) DIMENSIONS (mm)

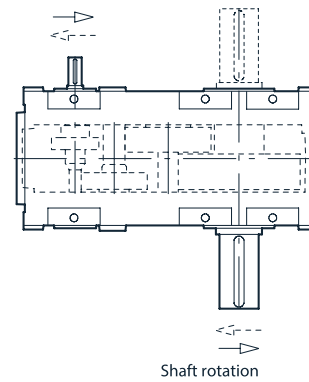
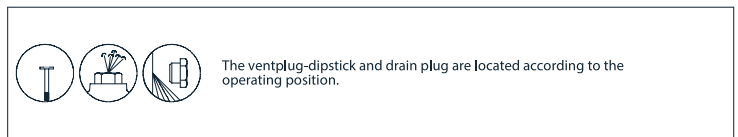
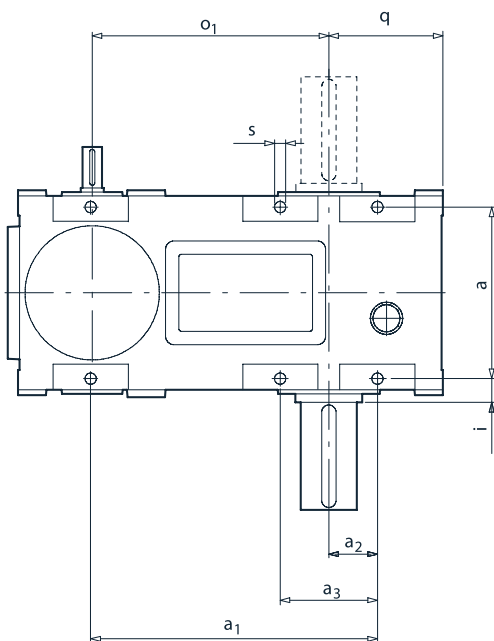
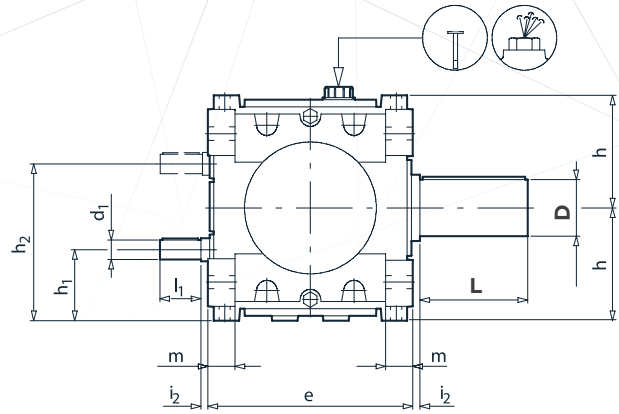
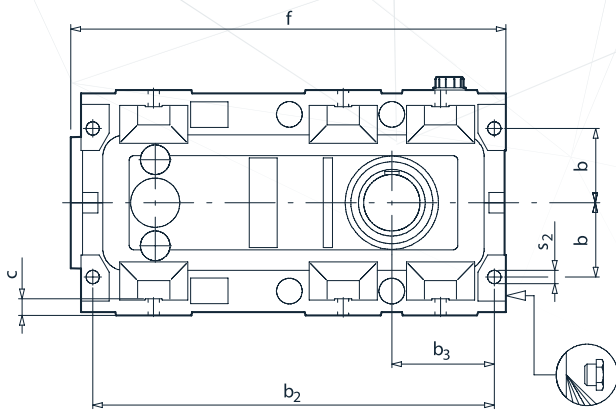

Size	[kg]	a	a ₁	a ₂	a ₃	b	b ₂	b ₃	c	e	f	h	h ₁	h ₂	i	i ₂	m	o ₁	q	s	s ₂	D	L	d ₁	l ₁
180	475	306	497	90	180	130	716	190	30	360	777	198	123	273	32	5	48	416	210	22	22	100	210	28	60
200	540	335	560	95	190	145	785	200	32	400	845	220	136	304	37.5	5	53	462	223	22	26	110	210	28	60
225	800	366	618	100	200	150	868	220	35	440	941	243	164	340	42	5	57	527	248	24	28	120	210	32	80
250	1170	386	710	125	270	210	970	255	32	480	1048	300	200	400	52	5	67	577	285	24	28	130	250	35	80
280	1455	430	790	135	270	230	1070	270	34	530	1160	320	212	428	55	5	60	599.5	308	26	30	140	250	38	80
320	1845	470	900	160	320	240	1223	303	34	580	1330	340	208	472	60	5	80	727	348	26	32	160	300	45	110
355	2335	495	1030	200	400	285	1395	380	45	630	1510	390	254	526	72.5	5	60	759.1	430	35	35	180	300	48	110

Approximate weights are shown in the tables. We reserve the rights to modify any dimensions, without changing the type number of reducers. For missing values please contact Technical Support.

BELL COUPLING INPUT

P1H (SINGLE STAGE) DIMENSIONS (mm)

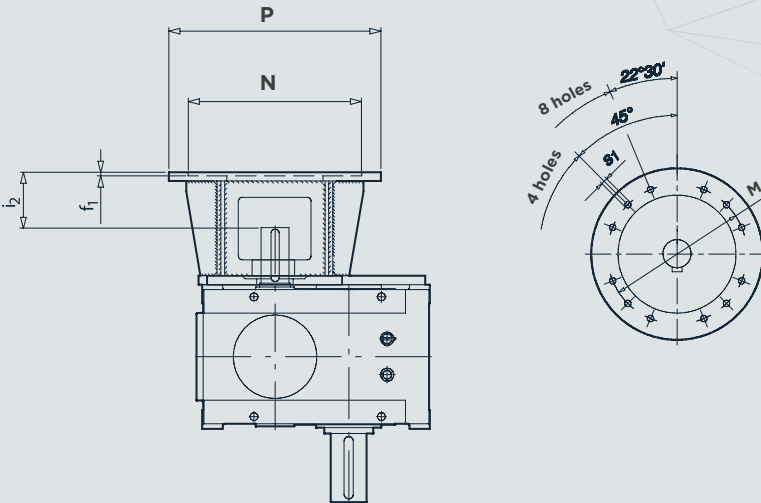

Size	d _{max}	P	N	M	f1	i2	s1	Nr. holes
180	75	550	450	500	10	147	M16	8

P2H (DOUBLE STAGE) DIMENSIONS (mm)

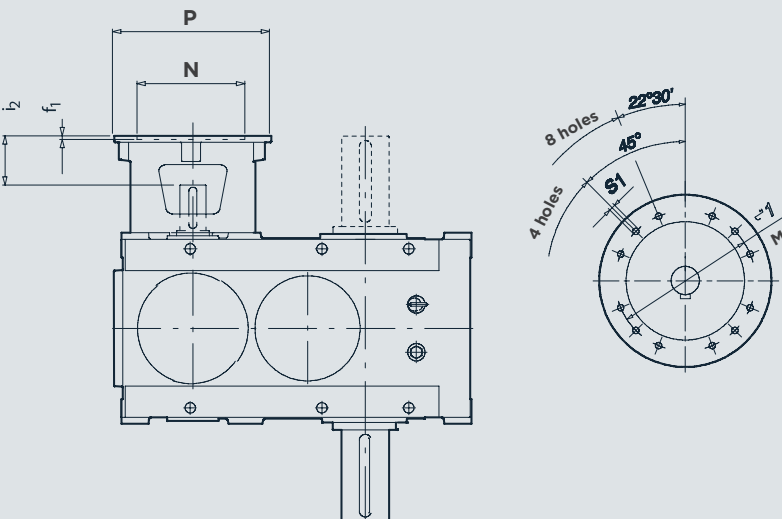

Size	d _{max}	P	N	M	f1	i2	s1	Nr. holes
180	75	350	250	300	8	115	M16	4
		*400	300	350	6	141	M16	4
		*450	350	400	6	144	M16	8
		*550	450	500	7	157	M16	8
200	75	350	250	300	6	122	M16	4
		*400	300	350	7	151	M16	4
		*450	350	400	6	151	M16	8
		*550	450	500	7	155	M16	8
225	75	350	250	300	6	117	M16	4
		*400	300	350	6	121	M16	4
		*450	350	400	6	144	M16	8
		*550	450	500	7	147	M16	8
250	75	350	250	300	8	117	M16	4
		*400	300	350	7	146	M16	4
		*450	350	400	6	147	M16	8
		*550	450	500	7	150	M16	8
280	60	450	350	400	6	126	M16	8

* With adaptation supplement

BELL COUPLING INPUT P3H (TRIPLE STAGE) DIMENSIONS (mm)

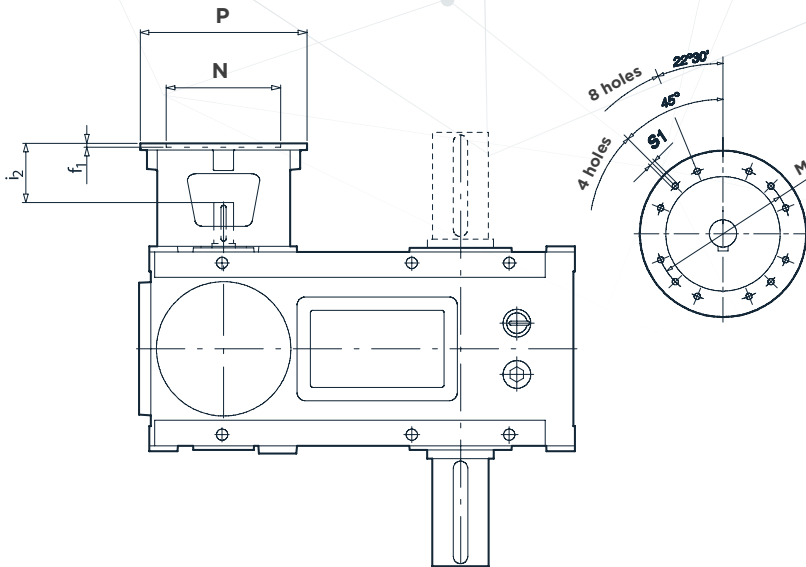

Size	d _{max}	P	N	M	f1	i2	s1	Nr. holes
180	48	250	180	215	7	92	M12	4
		300	230	265	7	96	M12	4
		*350	250	300	6	126	M16	4
200	48	300	230	265	5	84	M12	8
		*350	250	300	6	114	M16	4
225	75	350	250	300	16	122	M16	4
		*400	300	350	7	148	M16	4
		*450	350	400	7	151	M16	8
250	75	*550	450	500	7	155	M16	8
		350	250	300	8	117	M16	8
		*400	300	350	7	146	M16	4
280	60	*450	350	400	6	147	M16	8
		*550	450	500	7	172	M16	8
		350	250	300	8	118	M16	8
		*450	350	400	6	148	M16	8

* With adaptation supplement

P4H (FOUR STAGE) DIMENSIONS (mm)

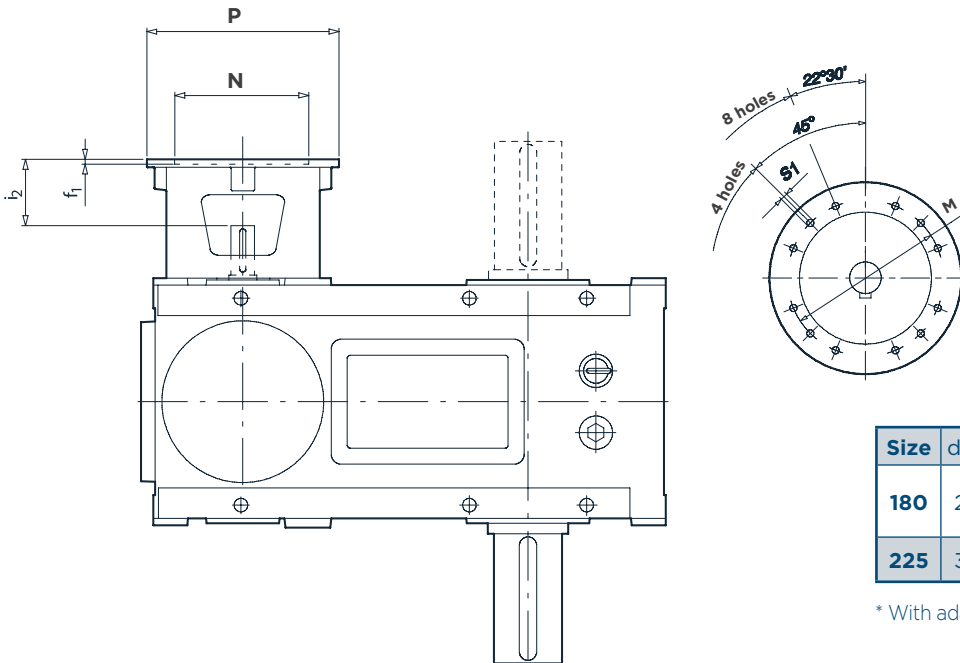

Size	d _{max}	P	N	M	f1	i2	s1	Nr. holes
180	28	200	130	165	16	74	M10	4
		*250	180	215	6	97	M12	4
225	38	300	230	265	7	118	M12	4

* With adaptation supplement

Performances

BEVEL HELICAL REDUCERS - B2H (DOUBLE STAGE)

			Gear reducer size						
			i						
			M _{N2} Nm						
			P _{N1} kW						
B2H - n ₁ = 1500 min ⁻¹	n _{N2}	i _N	180	200	225	250	280	320*	355*
	268	5,6	5,81	5,81	5,2	5,31	5,81	5,6	5,6
			7300	9300	11700	16400	22100	27000	34000
			207	262	369	504	622	800	900
	238	6,3	6,54	6,54	6,43	6,53	6,54	6,3	6,3
			8300	10500	14500	20100	24800	30000	38000
			207	262	369	504	622	800	1000
	211	7,1	7,65	7,53	7,5	7,37	7,58	7,1	7,1
			9700	12000	16900	22400	28800	35000	44000
			207	262	369	498	622	820	1020
	188	8	8,19	8,67	8,19	8,3	8,54	8	8
			10000	13100	18400	24400	32400	40000	50000
			200	246	369	482	622	830	1030
	167	9	9,47	9,21	9,47	8,81	9,29	9	9
			9000	10500	17200	19900	33100	40500	50500
			156	210	297	370	583	760	930
	150	10	10,4	9,76	9,60	9,60	9,54	10	10
			8500	8700	12400	23200	26000	31500	39500
			134	146	211	395	447	540	660
	134	11,2	11,4	10,8	11,2	10,8	11,1	11,2	11,2
8100			11200	14500	21300	30200	36500	46000	
117			169	211	323	447	540	690	
120	12,5	12,2	12,9	12,2	12,2	12,5	12,5	12,5	
		8700	11600	15800	24600	34000	41500	52000	
		117	146	211	331	447	550	690	
107	14	14,1	14,1	14,1	14,1	13,6	14	14	
		9200	12600	17500	23600	33700	41000	51500	
		107	146	202	275	407	490	610	
94	16	15,5	16,1	16,1	15,8	15,6	16	16	
		8700	11400	16000	21700	30000	36500	45500	
		91	116	163	225	316	385	490	
83	18	18,0	17,4	17,4	17,1	17,4	18	18	
		7600	10600	15000	20300	27600	33500	42000	
		69	100	141	194	260	315	390	
75	20	19,0	20,1	19,0	18,8	19,9	20	20	
		6000	7700	9500	16800	27800	33500	42500	
		52	63	81	146	229	280	355	
67	22,4	22,0	22,0	22,0	21,8	21,6	22,4	22,4	
		7000	8400	10900	19400	30200	36500	46000	
		52	63	81	146	229	275	345	
60	25	24,2	25,1	25,1	24,5	24,8	25	25	
		7600	9600	12500	21800	30700	37000	46500	
		52	63	81	146	202	250	310	
54	28	28,0	27,1	27,1	26,4	27,8	28	28	
		7700	10400	13500	20700	28400	34500	43000	
		45	63	81	128	167	210	260	

* For this size please contact Technical Support

BEVEL HELICAL REDUCERS - B3H (TRIPLE STAGE)

			Gear reducer size						
			i						
			M _{N2} Nm						
			P _{N1} kW						
B3H - n ₁ = 1500 min ⁻¹	n _{N2}	i _N	180	200	225	250	280	320*	355*
	60	25	25,3	23,9	24,0	26,2	23,9	25	25
			9400	12000	16300	26000	36500	44500	56000
			62	85	113	168	255	300	375
	54	28	27,5	27,5	29,6	29,2	26,9	28	28
			8700	13600	19700	25800	36000	44000	55000
			53	83	111	147	226	270	330
	48	31,5	29,8	31,9	31,8	31,7	32,2	31,5	31,5
			9400	15100	21200	28000	39000	47500	59500
			53	79	111	147	202	260	320
	42	35,5	33,5	36,8	37,1	35,8	37,4	35,5	35,5
			10600	15300	21000	29000	40000	49000	61500
			53	69	95	135	177	230	290
	38	40	39,2	42,3	40,5	40,3	39,2	40	40
			11100	13900	20300	27300	35600	43500	54500
			47	55	84	113	152	190	230
	33	45	44,5	46,3	44,2	47,3	47,0	45	45
			9100	13100	16900	25500	40000	49000	61500
			34	47	64	90	141	175	230
	30	50	50,0	47,7	47,5	50,7	49,0	50	50
10200			12900	18100	22700	31300	38000	47500	
34			45	64	75	107	130	170	
27	56	58,5	54,9	55,4	53,4	54,5	56	56	
		11200	14800	21100	28800	39500	48500	60500	
		32	45	64	90	121	150	190	
24	63	62,6	63,2	60,5	60,2	61,4	63	63	
		10700	14100	20700	27700	38000	46500	58000	
		29	37	57	77	103	130	160	
21	71	72,5	69,1	70,0	69,7	66,8	71	71	
		9500	13600	18400	25200	35600	43500	54500	
		22	33	44	61	89	105	130	
19	80	79,6	78,6	79,7	78,2	76,7	80	80	
		9400	11900	16800	23200	31800	38500	48500	
		20	25	35	50	69	85	105	
17	90	91,0	85,4	86,2	85,2	86,7	90	90	
		10200	12400	16000	21300	39400	48000	60500	
		19	24	32	42	76	95	120	
15	100	97,4	98,3	100	93,7	97,7	100	100	
		10900	14200	17000	24000	38600	47000	59000	
		19	24	30	43	66	80	105	
13	112	113	107	109	108	106	112	112	
		9600	13400	19300	25700	36400	44500	55500	
		14	21	30	40	57	70	90	
12	125	124	122	124	122	122	125	125	
		9800	12000	17100	23200	33000	40000	50500	
		13	17	23	32	45	55	70	
11	140	144	132	134	131	137	140	140	
		8200	11300	15900	21600	30000	36500	45500	
		9,6	14	20	28	36	45	60	

* For this size please contact Technical Support

BEVEL HELICAL REDUCERS - B4H (FOUR STAGE)

			Gear reducer size						
			i						
			M _{N2} Nm						
			P _{N1} kW						
n _{N2}	i _N	Gear reducer size							
		180	200	225	250*	280	320*	355	
15	100	102	104	97,8	100	102	100	104	
		11900	16700	21400	25500	37900	46000	76400	
		20	28	37	44	64	80	125	
13	112	115	114	113	112	109	112	112	
		9700	15000	21800	26000	28800	35000	76600	
		14	23	33	40	45	52	117	
12	125	120	119	120	125	121	125	118	
		11600	16100	21600	26000	32100	39000	76300	
		17	23	31	40	45	54	110	
11	140	136	148	141	140	133	140	138	
		10500	16200	20800	25000	38400	47000	76400	
		13	19	25	32	50	60	95	
9,4	160	153	155	151	160	159	160	152	
		11800	16900	22400	27000	38900	47500	76400	
		13	19	25	30	42	50	86	
8,3	180	170	171	176	180	172	180	173	
		10900	16000	22700	27000	38800	47500	76000	
		11	17	22	25	39	45	75	
7,5	200	198	196	191	200	190	200	194	
		11800	15200	21000	25000	39200	48000	76100	
		10	13	19	22	35	40	67	
6,7	224	212	212	235	224	232	224	220	
		11400	15000	22700	27000	38900	47500	76500	
		9,1	12	17	22	29	35	59	
6,0	250	253	238	252	250	237	250	243	
		11600	16900	17900	21500	38100	46500	76600	
		7,8	12	12	15	28	32	54	
5,4	280	278	265	274	280	269	280	271	
		12000	116400	23000	27500	38100	46500	75200	
		7,4	11	14	18	24	29	47	
4,8	315	297	305	299	315	303	315	303	
		11500	14900	21200	25500	39100	47500	76200	
		6,6	8,4	12	15	22	26	43	
4,2	355	344	371	346	355	371	355	345	
		10400	12700	18000	21500	38200	46500	75500	
		5,2	7,7	9,7	12	18	22	37	
3,8	400	394	380	394	400	379	400	380	
		11900	12700	18000	21500	34200	41500	76000	
		5,2	5,7	7,8	9,7	15	18	34	
3,3	450	461	427	431	450	430	450	433	
		12200	16800	23000	27500	38700	47500	75300	
		4,5	6,7	9,1	12	15	18	30	
3,0	500	493	491	470	500	484	500	484	
		11800	15200	22400	27000	37000	45000	75000	
		4,1	5,3	8,1	9,7	13	18	26	
2,7	560	571	537	544	560	545	560	551	
		10700	14500	20300	24000	31000	39000	74600	
		3,2	4,6	6,4	8,1	9,7	13	23	
2,4	630	627	612	620	630	605	630	620	
		10100	13000	18400	22000	34700	42000	54000	
		2,8	3,6	5,1	6,4	9,8	12	15	
2,1	710	727	660	669	710	676	710	685	
		8900	12300	17200	20500	31800	39000	61800	
		2,1	3,2	4,4	5,1	8	9,7	15	

* For this size please contact Technical Support

Dimensional drawings

B2H (DOUBLE STAGE) DIMENSIONS (mm)

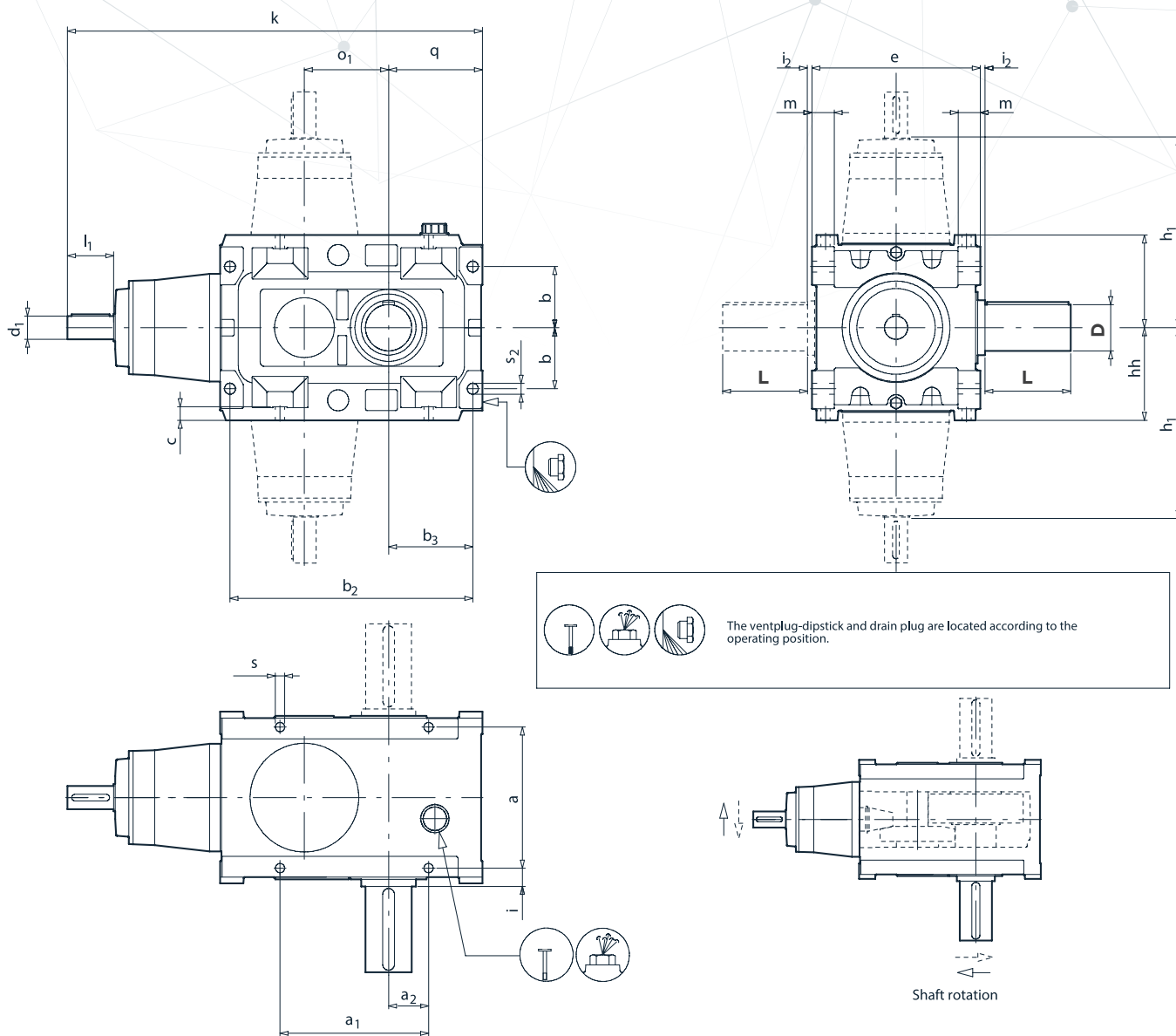

Size	[kg]	a	a ₁	a ₂	b	b ₂	b ₃	c	e	h	h ₁	i	i ₂	k	m	o ₁	q	s	s ₂	D	L	d ₁	l ₁
180	375	306	306	85	130	530	190	30	360	198	420	32	5	920	48	180	210	22	22	100	210	48	110
200	490	335	353	95	145	577	200	32	400	220	453	37.5	5	986	53	200	223	22	26	110	210	55	110
225	660	366	390	100	150	640	220	35	440	243	486	42	5	1099	57	225	248	24	28	120	210	60	140
250	810	386	450	125	210	720	255	32	480	300	522	52	5	1195	67	250	285	24	28	130	250	65	140
280	990	430	520	135	230	805	270	34	530	320	587	55	5	1315	60	280	308	26	30	140	250	70	140
320	1230	470	685	160	240	908	303	34	580	340	590	60	5	1410	80	315	348	26	32	160	300	80	170
355	1510																						

Approximate weights are shown in the tables. We reserve the rights to modify any dimensions, without changing the type number of reducers. For missing values please contact Technical Support.

B3H (TRIPLE STAGE) DIMENSIONS (mm)

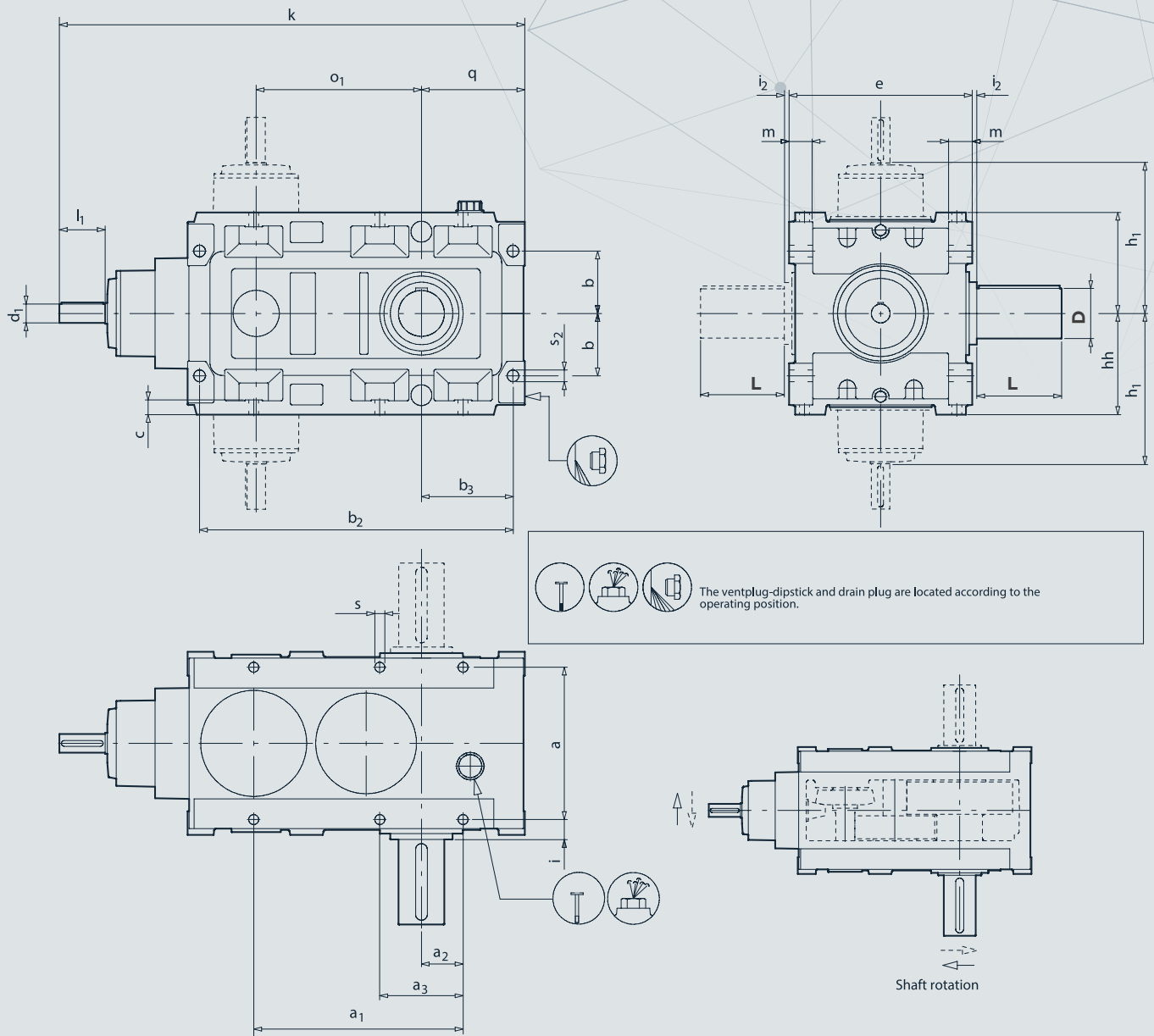

Size	[kg]	a	a ₁	a ₂	a ₃	b	b ₂	b ₃	c	e	h	h ₁	i	i ₂	k	m	o ₁	q	s	s ₂	D	L	d ₁	l ₁
180	435	306	410	85	-	130	634	190	30	360	198	319	32	5	925	48	317	210	22	22	100	210	38	80
200	530	335	450	95	190	145	674	200	32	400	220	348	37.5	5	1033	53	352	223	22	26	110	210	42	110
225	680	366	503	100	200	150	753	220	35	440	243	373	42	5	1128	57	397	248	24	28	120	210	48	110
250	980	386	570	125	250	210	830	255	32	480	300	390	52	5	1225	67	440	285	24	28	130	250	55	110
280	1110	430	635	135	270	230	966	270	34	530	320	450	55	5	1391	80	493	308	26	30	140	250	60	140
320	1470																							
355	1970	495	825	200	400	285	1220	380	45	630	390	550	72.5	5	1765	60	625	430	35	35	180	300	75	140

Approximate weights are shown in the tables. We reserve the rights to modify any dimensions, without changing the type number of reducers. For missing values please contact Technical Support.

B4H (FOUR STAGE) DIMENSIONS (mm)

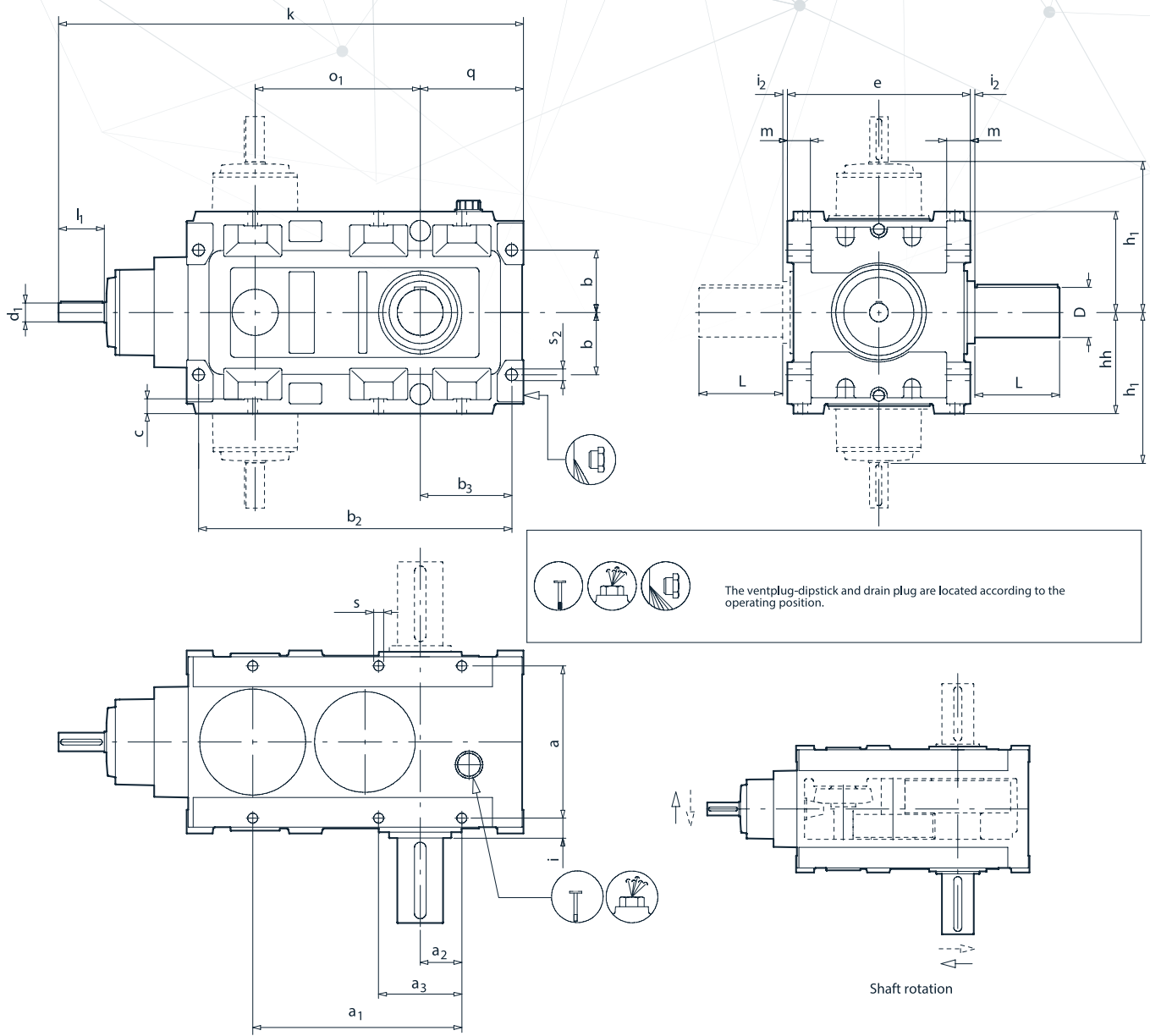

Size	[kg]	a	a ₁	a ₂	a ₃	b	b ₂	b ₃	c	e	h	h ₁	i	i ₂	k	m	o ₁	q	s	s ₂	D	L	d ₁	l ₁
180	475	306	497	90	180	130	716	190	30	360	198	270	32	5	956	48	416	210	22	22	100	210	28	60
200	545	335	560	95	190	145	785	200	32	400	220	335	37.5	5	1068	53	457.2	223	22	26	110	210	32	80
225	810	366	618	100	200	150	868	220	35	440	243	348	42	5	1203	57	527	248	24	28	120	210	38	80
250	1190																							
280	1470	430	790	135	270	230	1070	270	34	530	320	493	55	5	1478	60	624.6	308	26	30	140	250	42	110
320	1870																							
355	2360	495	1030	200	400	285	1395	380	45	630	390	575	72.5	5	1830	60	789.3	430	35	35	180	300	50	110

Approximate weights are shown in the tables. We reserve the rights to modify any dimensions, without changing the type number of reducers.
For missing values please contact Technical Support.

BELL COUPLING INPUT

B2H (DOUBLE STAGE) DIMENSIONS (mm)

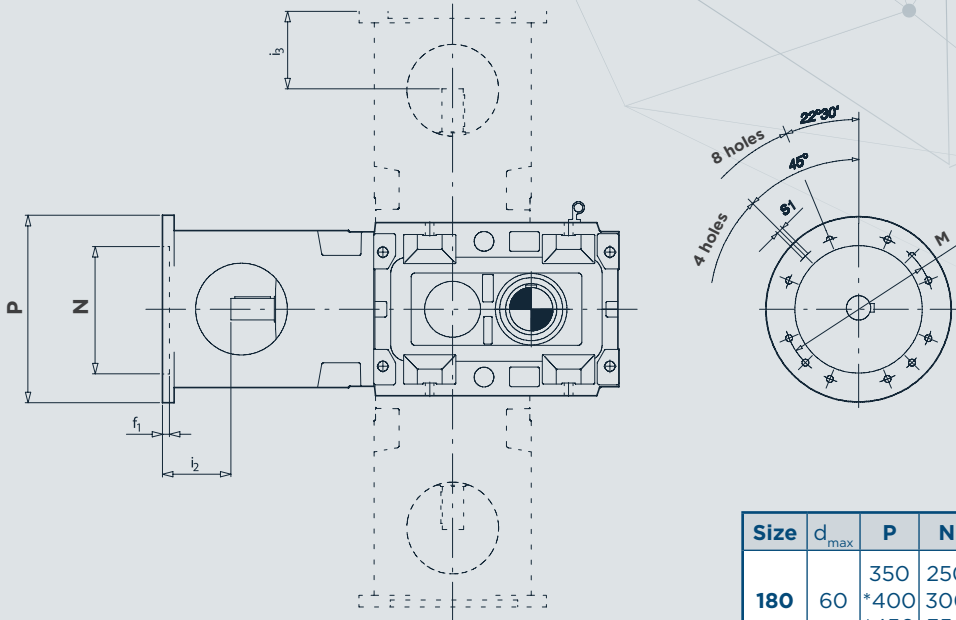

Size	d _{max}	P	N	M	f1	i2	i3	s1	Nr. holes
180	60	350	250	300	6	114	132	M16	8
		*400	300	350	7	143	162	M16	4
		*450	350	400	6	144		M16	8
200	55	400	300	350	6	116		M16	8
225	60	450	350	400	6	129	149	M16	8

* With adaptation supplement

B3H (TRIPLE STAGE) DIMENSIONS (mm)

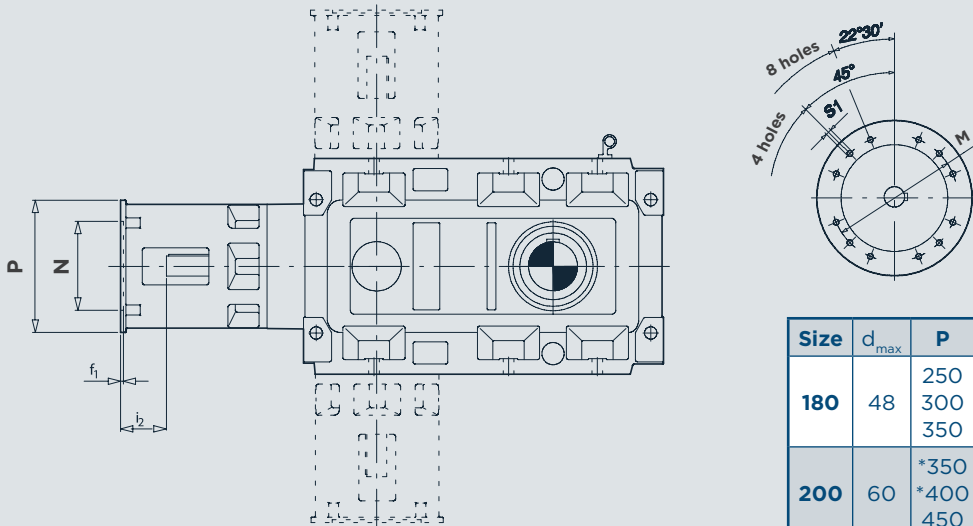

Size	d _{max}	P	N	M	f1	i2	s1	Nr. holes
180	48	250	180	215	5	62	M12	4
		300	230	265	5	84	M12	
		350	250	300	6	114	M16	
200	60	*350	250	300	6	114	M16	4
		*400	300	350	6	124	M16	4
		450	350	400	6	147	M16	8
225	55	350	250	300	6	115	M16	4
		*400	300	350	7	143	M16	4
250	60	350	250	300	7	144	M16	8
		*400	300	350	7	173	M16	8
		*450	350	400	7	173	M16	8
280	75	350	250	300	7	114	M16	8
		*450	350	400	6	149	M16	8
		*550	450	500	7	147	M16	8

* With adaptation supplement

B4H (FOUR STAGE) DIMENSIONS (mm)

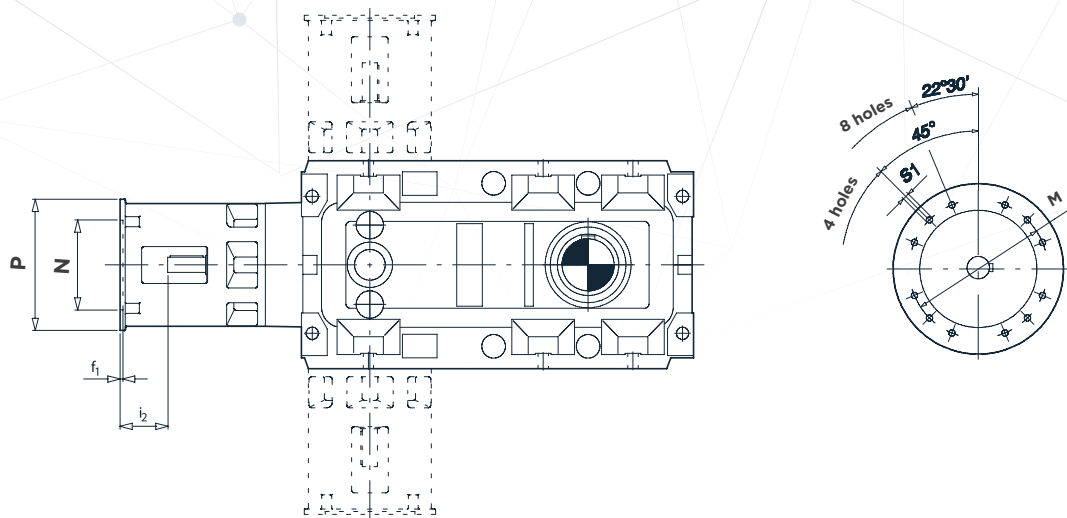

Size	d _{max}	P	N	M	f1	i2	s1	Nr. holes
180	28	200	130	165	18	74	M10	4
		*250	180	215	8	97	M12	4
280	48	300	230	265	5	84	M12	8
		*350	250	300	6	114	M16	4

* With adaptation supplement

8 ACCESSORIES AND OPTIONS

OUTPUT SHAFT VERSIONS
Hollow low speed shaft with keyway
Hollow low speed shaft with shrink disc
Hollow low speed shaft with front holes
Oversized and downsized hollow low speed shaft
Stepped hollow low speed shaft
Splined hollow low speed shaft
Double integral low speed shaft
Single/Double splined integral low speed shaft

OIL AND LEVEL DEVICE
Bearing lubrication pump
Bearing lubrication motorpump
Oil temperature probe PT100
Bearing temperature probe PT100
Bimetallic thermostat probe
Pressure switch
Electric signaling device of filter clogging
Oil level switch with float
Oil level column
Infrared oil level probe

COOLING AND HEATING DEVICE
Cooling fan
Cooling water with coil with or without thermostatic valve
Independent cooling unit oil/water or oil/air
Oil heater

ACCESSORIES
Backstop device
Protection for hollow low speed shaft
Protection for hollow low speed shaft with shrink disc
Hollow low speed shaft washer
Output flange
Reaction bolt with spring disc
Reaction arm
Special anticorrosion painting
Labyrinth seals with greaser on high and low speed shaft
Fluoro rubber seals
Vent plug with filter
Magnetic plug
NEMA adaptor input flange

Hollow low speed shaft

HOLLOW LOW SPEED SHAFT WITH KEYWAY

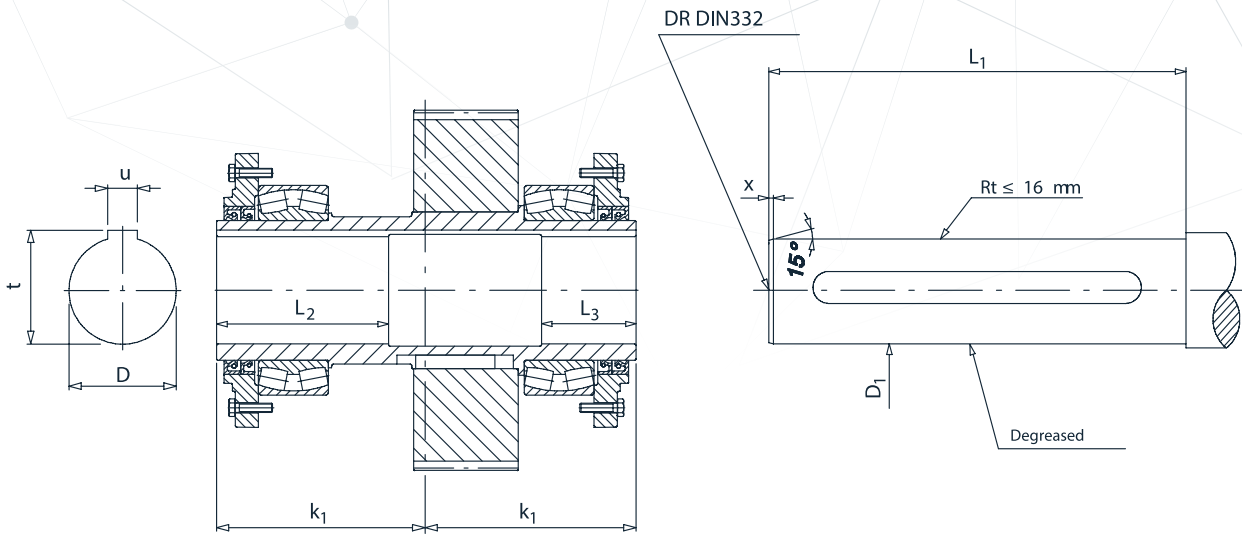

HOLLOW LOW SPEED SHAFT WITH SHRINK DISC

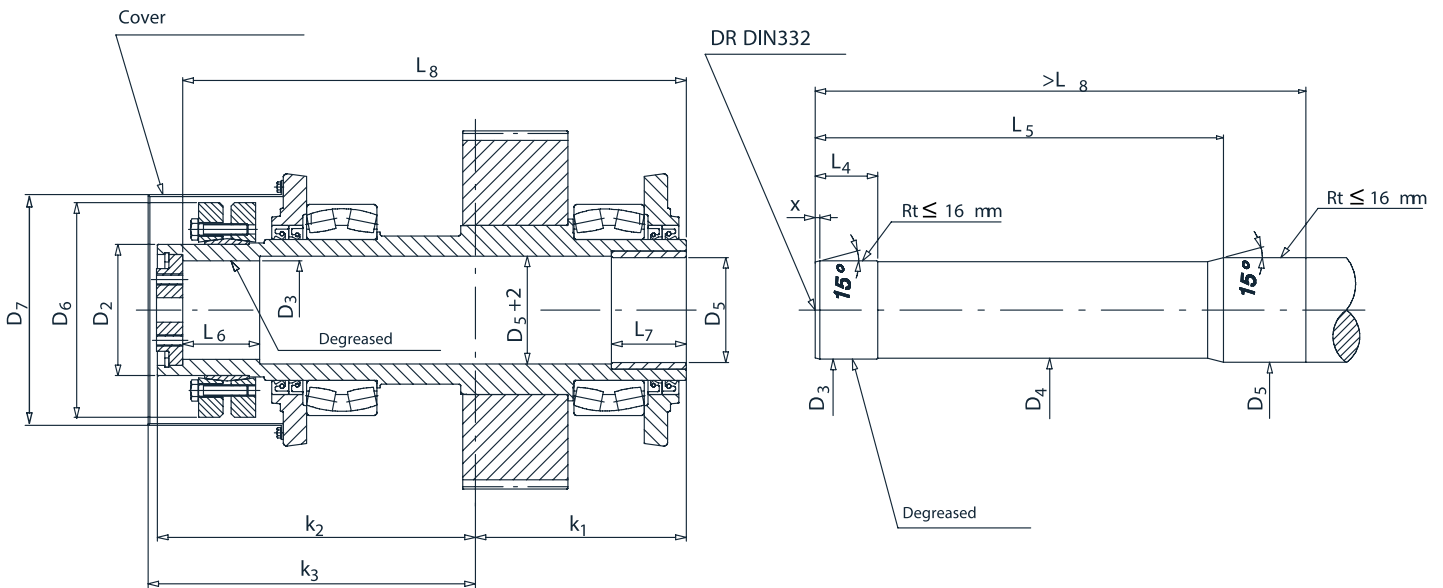

Size	D (H7)	D ₁ (h6)	D ₂ (h6)	D ₃ (H7/g7)	D ₄	D ₅ (H7/f7)	D ₆	D ₇	k ₁	k ₂	k ₃	L ₁	L ₂	L ₃	L ₄	L ₅	L ₆	L ₇	L ₈	t	u (H8)	x
180	90	90	115	90	88	95	188	226	185	273	285	368	145	80	80	372	78	60	434	95.4	25	5
200	100	100	125	105	103	106	215	232	205	289	298	408	160	95	80	389	76	75	469	106.4	28	5
225	115	115	140	110	108	112	230	246	225	339	355	448	184	102	85	452	82	80	537	122.4	32	5
250	125	125	155	120	118	122	265	300	245	377	387	488	185	105	120	492	110	80	592	132.4	32	5
280	140	140	165	130	128	132	290	305	270	390	400	538	223	122	120	530	110	80	630	148.4	36	5
320																						
355	170	170	195	155	152	158	350	370	320	460	470	638	260	150	160	640	140	90	750	179.4	40	5

For missing values please contact Technical Support.



www.motovario.com